

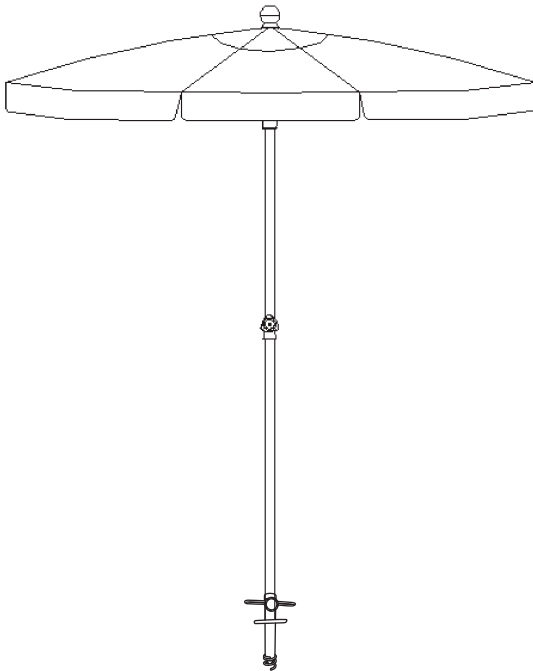

SimplyShade®

Tahiti
Beach Umbrella

6.5' Octagon / SSUB865



Instruction Manual

Thank you for purchasing SimplyShade's Tahiti Beach Umbrella.

Please remove all contents from the package, inspect and review checklist.
CAUTION: To reduce personal injury and damage to your umbrella, read and follow this assembly and operation guide. *Save information for future reference.*

CHECKLIST

- A - (1) Top Pole/Canopy
- B - (1) Bottom Pole
- C - (1) Sand Anchor*
- D - (1) Carry Bag

*Separate box

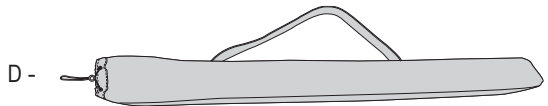
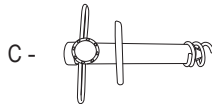
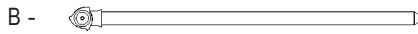
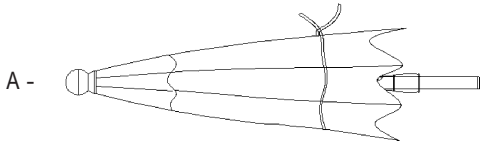

STEP 1 Install Sand Anchor

Using the handles, twist the sand anchor clockwise (Fig. 1) until the plate reaches the sand (Fig. 2). NOTE: May be necessary to use body weight while twisting sand anchor down.

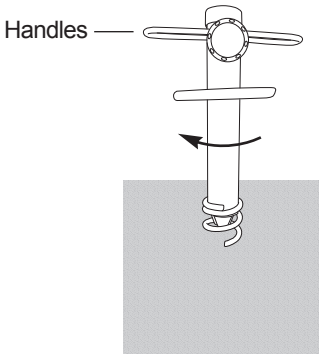

(Fig. 1)

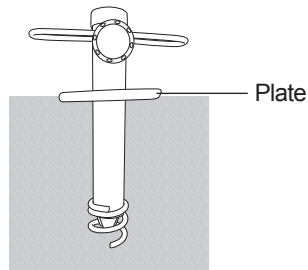

(Fig. 2)

STEP 2 Set Up Beach Umbrella

Remove bottom pole and top pole with canopy from carry bag. Insert the top pole with canopy into the bottom pole (Fig. 3). Turn the knob clockwise to tighten poles together (Fig. 4). Insert bottom pole into sand anchor (Fig. 5). Tighten knob on sand anchor by turning clockwise to secure (Fig. 6).

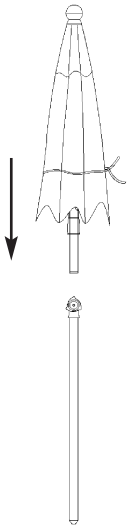

(Fig. 3)

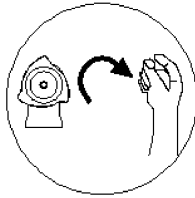

(Fig. 4)

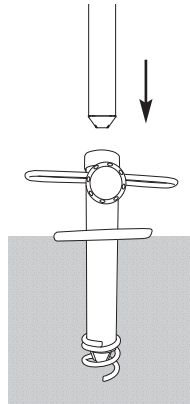

(Fig. 5)

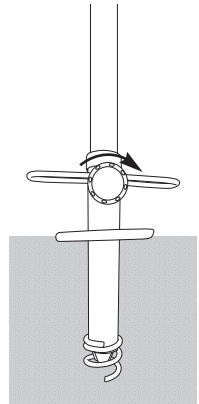

(Fig. 6)

STEP 3 Opening Beach Umbrella

Untie the strap on the canopy and open the umbrella by pushing the runner upward until the runner (Fig. 7) reaches the top and locks into place. Your umbrella is now open and ready for use (Fig. 8).

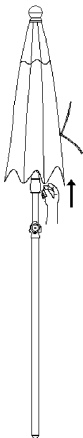

(Fig. 7)

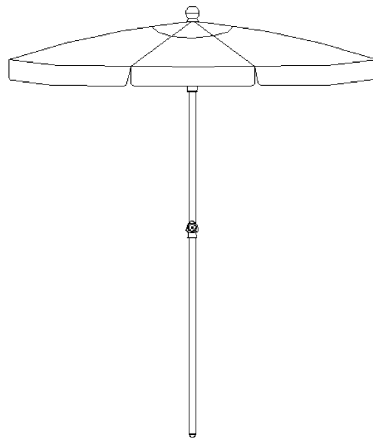

(Fig. 8)

STEP 4 Tilting Beach Umbrella

Lift the lock tube with one hand (Fig. 9) and gently grab a rib of the umbrella with the other hand and pull down (Fig. 10). The umbrella will tilt in the direction you pulled down at a 30° angle. To bring back to upright position, put one hand on the lock tube and grab the end of the umbrella with the other hand and push up back to upright position. NOTE: Do not tilt umbrella when the umbrella is not fully opened.

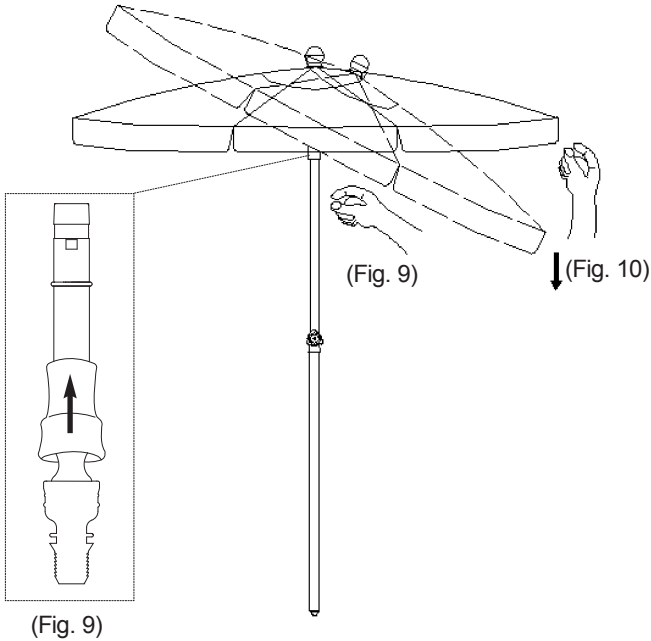

ROTATION:

The umbrella can rotate 360° while in the tilt position.

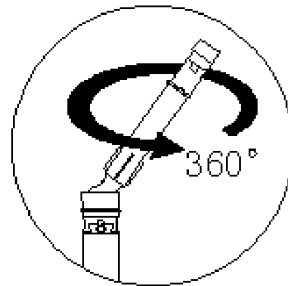

STEP 5 Closing Beach Umbrella

With the umbrella in a level position, push the button on the runner to unlock the runner from the pole. Hold runner and slide down pole slowly until the canopy is closed (Fig. 11). Tie strap around canopy to secure.

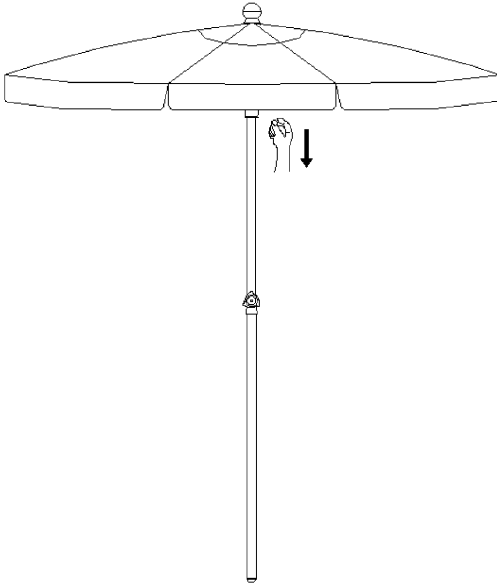

(Fig. 11)

STEP 6 Disassembling Beach Umbrella

Turn the knob on the umbrella counter-clockwise to loosen (Fig. 12). Remove the top pole with canopy from the bottom pole (Fig. 13). Loosen sand anchor knob by turning counter clockwise and remove the bottom pole from the sand anchor (Fig. 14). Store top pole with canopy and bottom pole in carry bag (Fig. 15).

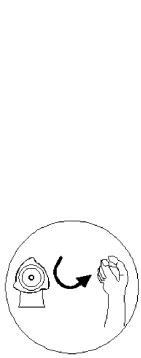

(Fig. 12)

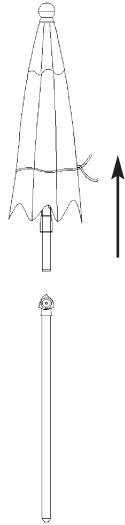

(Fig. 13)

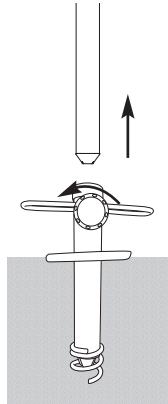

(Fig. 14)

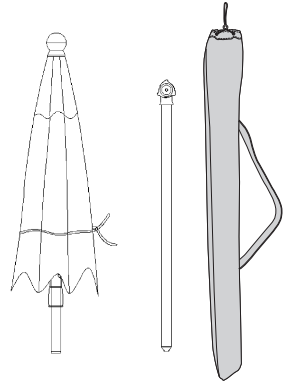

(Fig. 15)

STEP 7 Removing Sand Anchor

Simply rock the sand anchor back and forth in the sand to loosen. Pull sand anchor out of sand using handles (Fig. 16). Dust off excess sand and store away.

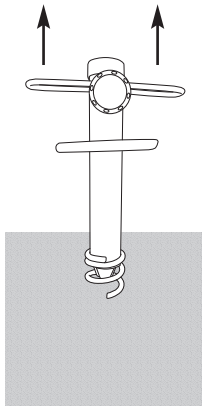

(Fig. 16)

S A F E T Y P R E C A U T I O N S :

- To reduce risk of personal injury in which a person is injured or harmed, and/or damage to personal property, read and follow the Assembly Guide prior to assembling and operating umbrella and sand anchor.
- Close and store the umbrella in windy conditions or when a storm approaches. Never allow the umbrella to flap in the wind; this could cause personal injury, damage to personal property, damage to umbrella and/or umbrella canopy. Do not use tilting function during windy conditions.
- Keep umbrella secured to sand anchor at all times.
- Do not leave open umbrella unattended. If damage occurs, this is not covered by the warranty.
- When adjusting the umbrella, make sure that no person(s), item(s) or personal property are close to the umbrella. This is important to prevent injury or material damage.
- Do not allow children to play on or with umbrella or sand anchor.
- When adjusting or assembling the umbrella or sand anchor, make sure fingers, toes or any other parts of the body are clear from moving parts. Failing to do so may result in serious injury.

C A R E A N D M A I N T E N A N C E :

- When not in use, close and cover umbrella in carry bag.
- Allow a wet canopy to dry while in open position.
- If necessary, clean the fabric with lukewarm water, mild detergent, and a sponge.
- Wipe sliding marks on the aluminum poles with a damp cloth.

WARRANTY:

SimplyShade warrants this product (in residential use) to be free from defects in original materials and workmanship for a period of 1 year from the date of purchase. If a defect in the original material or workmanship appears during the warranty period; SimplyShade will (at its option) repair or replace the product without charge. Limited warranty against fabric fading, depending on fabric.

Please contact your original authorized SimplyShade dealer with a description of the defect. The dealer will verify the defect and work closely with SimplyShade to obtain the necessary service. In many cases, simple problems can be solved with a replacement part that can be shipped directly to the dealer for professional installation/repair.

In the event that warranted factory service is required, SimplyShade will assume the responsibility of the return freight charges on warranted product for 1 year only.

Returned product that (upon receipt and inspection) is deemed to be “not covered” under our warranty, will be shipped/billed at your expense.

This warranty gives you specific legal rights, and you may have other rights which vary from state to state.

NOTE: Failure caused by unreasonable or abusive use, or failure caused by neglect of reasonable and necessary care are not covered by this warranty.

Additionally, acts of nature (including but not limited to wind, hurricanes, tornadoes, and storms) are not covered by this warranty.



www.simplyshade.com