

Assembly Instructions

Red Cedar Picnic Table



Tools Needed:

7/16" Socket or Adjustable Wrench
#2 Square Drill Bit (included)
Hammer for tapping bolts & screws

Parts List:

5 or 6 Table Boards (27" or 32" Tables)
2 Table Beams
2 Upper Leg Beams
2 Lower Leg Beams
4 Leg Posts
2 Braces

Hardware:

16 3" x 1/4" Hex Bolts
4 2 1/2" x 1/4" Hex Lag Screws
16 1/4" Hex Nuts
32 1 1/4" Large Washers
4 1/4" Small Washers
+20 2 1/2" Screws

Please read all instructions thoroughly before assembling your table.

STEP 1 **TABLE TOP** - Lay the Table Boards upside down on a clean and flat surface (blanket or sheet recommended) with the rounded edges facing down. The slanted corners on 2 of the boards go on the outside of the Table Top, and the other boards go in the middle. If your table has an umbrella hole, make sure the board(s) with a hole are in the center of your Table Top.

NOTE: 27" tables have 5 Table Boards and 32" tables have 6.

STEP 2 Measure 8" inward from one end of the Table Boards and fasten a Table Beam with 2 1/2" screws, 2 per Table Board. Make sure the longest flat edge of the Table Beam is against the Table Boards.

NOTE: Do not block the Side Holes in the Table Beams, they will be used in STEP 8 when attaching the Leg Assemblies.

STEP 3 Repeat STEP 2 at the other end of the table to attach the second Table Beam.

STEP 4 Attach the Center Table Beam (3/4" slat) in the middle of the Table Boards the same way, but make sure it avoids the optional 2" Umbrella Hole if your table has one.

STEP 5 **LEG ASSEMBLY** - Lay the leg posts down vertically. Then lay the Upper and Lower Leg Beams horizontally at the top and center of the 2 Leg Posts, respectively. Push 3" bolts with Large Washers through the Upper and Lower Leg Beams (4 bolts per beam). The Upper Holes in the Upper Leg Beams will be used later.

STEP 6 When all the bolts with washers are pushed through both Leg Beams, align the bolts with the holes in the Leg Posts and push them through. Put a washer and a nut on each bolt and tighten.

STEP 7 Repeat STEP 5 & 6 to assemble the second Leg Assembly.

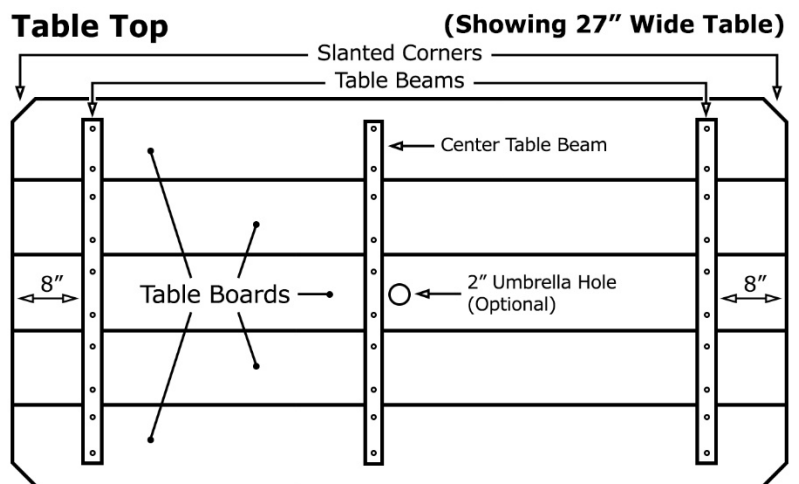

Leg Assembly

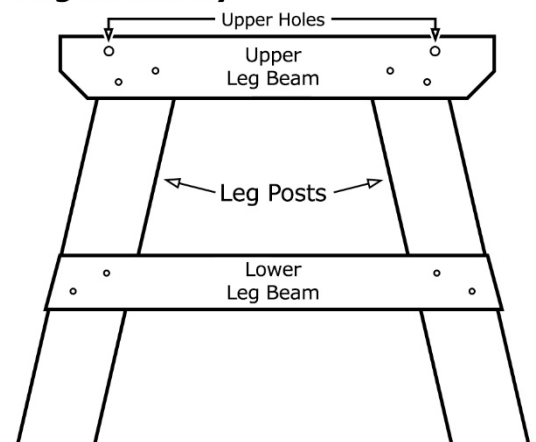

Finalize

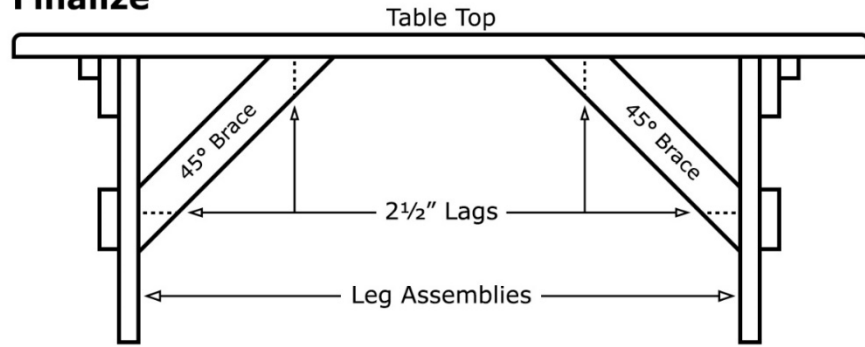

- STEP 8 **FINALIZE** – Attach one Leg Assembly to the Table Top using a 3" bolt, 2 washers, and a nut for each Upper Hole in the Upper Leg Beams (4 holes total, 2 per Leg Assembly). The leg beams go on the inside of the Table Beams when they attach to each other.
- STEP 9 Take a 45° Brace and attach it to the center of the Lower Leg Beam and the Bench Seat using 2 1/2" lags with small washers.
- STEP 10 Repeat STEP 8 & 9 to attach the other Leg Assembly and 45° Brace.
- STEP 11 Tighten all nuts, bolts, and screws.

This Completes Assembly. Enjoy your new Red Cedar Picnic Table!



Assembly Instructions

Red Cedar Traditional Bench



Tools Needed:

7/16" Socket or Adjustable Wrench
#2 Square Drill Bit (included)
Hammer for tapping bolts & screws

Parts List:

3 Bench Boards
2 Bench Beams
2 Upper Leg Beams
2 Lower Leg Beams
4 Leg Posts
2 Braces

Hardware:

16 3" x 1/4" Hex Bolts
4 2 1/2" x 1/4" Hex Lag Screws
16 1/4" Hex Nuts
32 1 1/4" Large Washers
4 1/4" Small Washers
12 2 1/2" Screws

Please read all instructions thoroughly before assembling your bench.

STEP 1 **BENCH SEAT** - Lay the 3 Bench Boards upside down on a clean and flat surface (blanket or sheet recommended) with the rounded edges facing down. The narrow board goes in the center, the slanted corners on the other 2 boards go on the outside of the bench seat.

Bench Seat

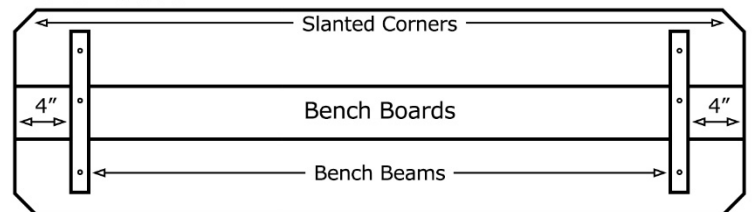

STEP 2 Measure 4" inward from one end of the Bench Boards and fasten a Bench Beam with 2 1/2" screws. Make sure the longest flat edge of the Bench Beam is against the Bench Boards. Repeat this step at the other end of the seat to attach the second Bench Beam.

STEP 3 **LEG ASSEMBLY** – Lay the leg posts down vertically. Then lay the Upper and Lower Leg Beams horizontally at the top and center of the 2 Leg Posts, respectively. Fasten using 3" bolts with Large Washers: the Upper and Lower Leg Beams get 4 bolts each. (The center holes in both Leg Beams will be used in the next step.) When all the bolts with washers are pushed through the Leg Beams, align the bolts with the holes in the Leg Posts and push them through. Put a washer and a nut on each bolt and tighten. Repeat this step for the second Leg Assembly.

Leg Assembly

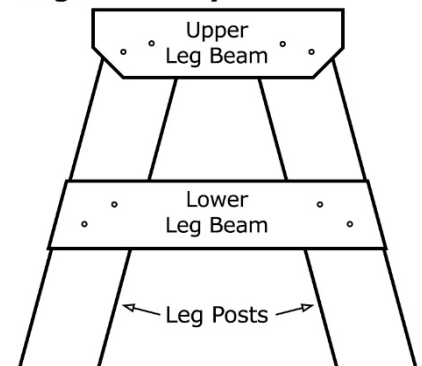

STEP 4 **FINALIZE** – Attach one leg assembly to the Bench Seat with a 3" bolt, 2 washers, and a nut using the middle hole in the Upper Leg Beam that was not used previously. The leg beams go on the inside of the top beams when they attach to each other. Then take a 45° Brace and attach it to the center of the Lower Leg Beam and the Bench Seat using 2 1/2" lags with small washers. Repeat this step to attach the other Leg Assembly and 45° Brace.

Bench Finished

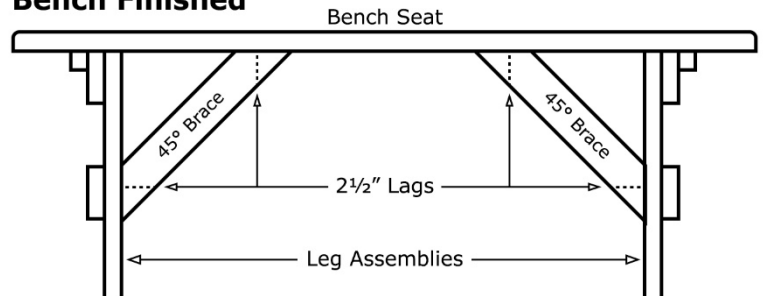

STEP 5 Tighten all nuts, bolts, and screws... and enjoy your new Red Cedar Traditional Bench!