



2-PIECE (AQ20-2) POTTING BENCH

Page 1

MATERIALS LIST:

- 1 - Top Shelf Section
- 2 - Side / Leg Sections
- 1 - Working Shelf Section
- 1 - Bottom Shelf Section
- 1 - 1 x 6 x 46 1/2" Back Splash
- 2 - 1 x 6 x 48" Fascia Board
- 2 - 1 x 6 x 22" Fascia Board
- 2 - 1 x 4 Diagonal Braces
- 1 - Mixing Tub
- 62 - 2" Zinc Coated Screws
- 4 - 3" Zinc Coated Screws
- 1 - 1x4 Top Shelf Base
- 2 - 2x4 Top Shelf Vertical Supports
- 1 - Driver Bit

INSTRUCTIONS:

1. Assemble Top Shelf Unit by positioning 2x4 uprights flush into the corners of the Preassembled Top Shelf and fasten with 2" Screws as shown (1A). Now attach bottom anchor board to the underside of the 2x4 uprights with 3" Screws.
2. Position Bottom Shelf Unit. (2A) Fasten down to 2x4's at each end with 2" Screws.
3. Position Working Shelf Unit as shown. (2B) Fasten down to 2x4's at each end with 2" Screws.

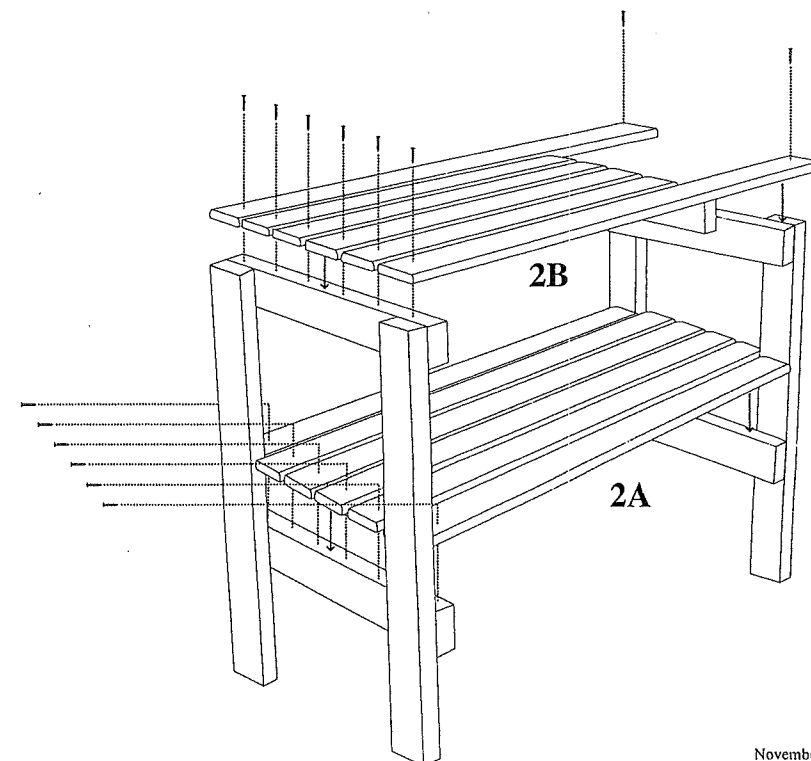
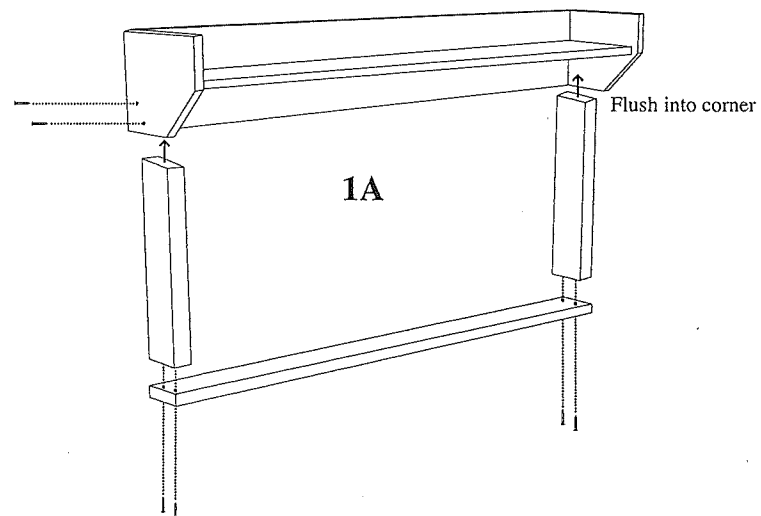



2-PIECE (AQ20-2) POTTING BENCH

Page 2

4. Install 1x6 Fascia Board (48") to the front of the Top Shelf Unit flush with the top and overhang both sides 3/4".(3A) Fasten 2 screws into each 2x4 Side / Leg Section. Install 2 additional screws through the Fascia Boards into the 2x4 bucket support. Now install the 2 Side Fascia Boards by butting them up to the Front Fascia, flush with the Top Shelf Unit. (3B)
5. Attach the assembled Top Shelf Unit to the top of the Working Shelf Unit with 2" Screws. (4A)
6. Fasten Down Side Trim using 2" Screws. (5A)

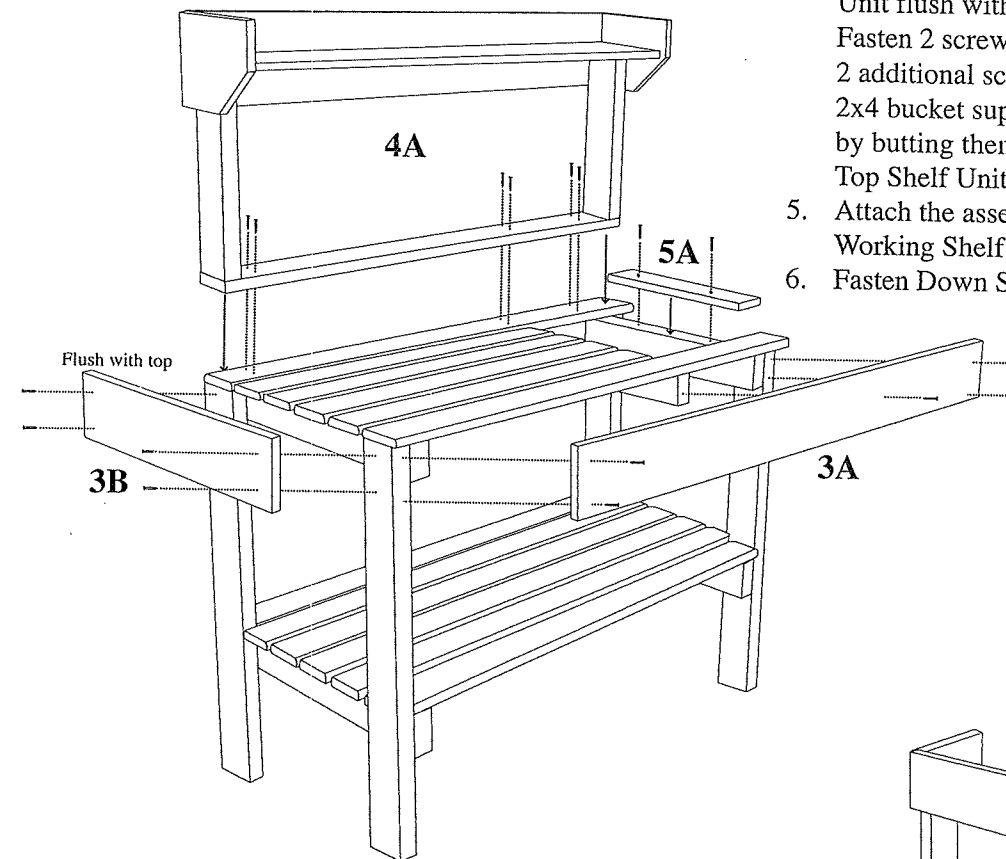

7. Position 1x6 Fascia Board (48") flush with the side Fascia Boards as shown and attach using 2" Screws. (6A) Now position 1x6 Back Splash (46 1/2") on top of the Fascia Board and attach using 2" Screws. (6B)
8. Make sure the bench is square and attach 1x4 Diagonal Braces (7A) using 2" Screws and fasten into 2x4 Leg Section and then to the back of the Bottom Shelf Unit.
9. Drop Mixing Tub into place.

