



Assembly Instructions

Crossleg Table Set



*Thank you for choosing **A&L Furniture Co.***

We hope that this piece brings you many years of enjoyment!

For help with assembling your furniture,
or if you have missing hardware, please email us at
help@aandlfurniture.com or call us at 866-896-5747

PARTS

(A) Table Top (1)

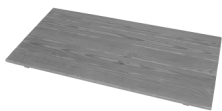

(B) Benches (2)



(C) Table Legs (2)



(D) Bench legs (4)

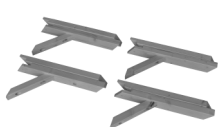

HARDWARE (included)

2" Bolts (12)

(a)



2" Lag Screws (6)

(b)



Allen Wrench (1)

(c)



TOOLS NEEDED

$\frac{7}{16}$ " Wrench or Socket

STEP 1

Lay table top upside down on a clean surface. Unfold table legs creating an X. Place legs on table top with one side outside 2x2 on table top & other side inside 2x2. Angle brace belongs toward center of top. Put a 2" bolt through the predrilled hole in each leg & turn into the threaded inserts in the 2x2 strip. Tighten with the Allen wrench. The bolts go in opposite sides, always put through the leg first.

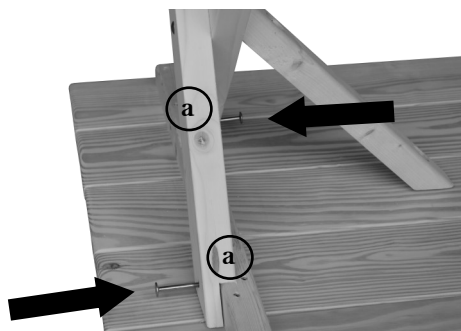
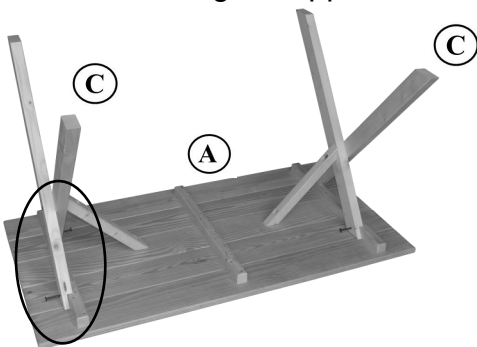

STEP 2

Attach the leg braces to the table top. Place the braces in the center of the board & attach with 2" lag screws using a $\frac{7}{16}$ " wrench or socket. Holes are not predrilled as lags are self drilling.

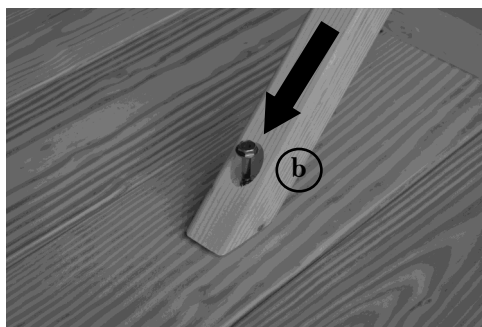
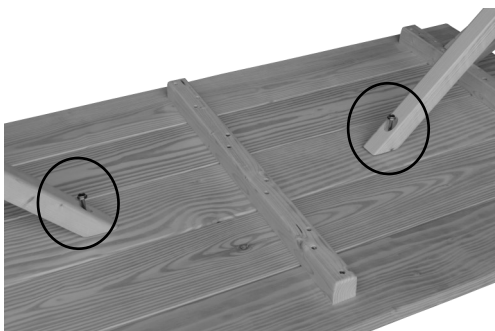

STEP 3

Follow the same steps as above for assembling the benches. When attaching the braces place braces on opposite boards & not the crack between the boards.

