

Porch Glider Assembly Instructions

Models: WF1205CVD, WF1215CVD, WF1225CVD, WF2SEGCVD, WF4SEGCVD, WF5SEGCVD, WF6SEGCVD
WRF3230SETCVD, WRF3200COLCVD

The item can be found on
www.CedarwoodFurniture.com

Call 877-595-8537 to order

- Step 1 Lay out all the parts and identify each one by comparing them with the drawings.
- Step 2 Fasten the seat and back assemblies together with the 5-1/2" long bolts. Then tighten with 7/16" socket. Using small washers on each end of bolts.
- Step 3 Fasten the Arm & Leg Assemblies to the seat with the 3" bolts.
Put a large washer on each end of the bolts. Put (1) large washer on bolt then slide through leg from outside ... then through seat. Add the other large washer then 1/4" nut and hand tighten. Fasten the arms to the back with the two 3" carriage (smooth head) bolts. Use a small washer under the nut only.
- Step 4 Attach the stabilizer board to the front legs, and up against the bottom of the seat, with 4 short screws, turning it so the notches fit over the legs
- Step 5 Attach the board with the heart cutouts, to the top of the back, with the 1-5/8" screws provided. Leave the same space between it and the top slat, as there is between the rest of the slats. (this board is left off to avoid damage during shipping).
- Step 6 Assemble the base using four 2-1/2" screws, four down through the top and two 3" in from each end. The feet are also mirror images of each other. Make sure the steel hangers are to the outside.
- Step 7 Now slide the base in under the seat making sure that the hangers closest to the end of base are in front. The steel hangers on the front of the base are shorter, and closer to the end, than the back ones. (If the base is turned wrong, the glider seat will lean too far forward, and will not be as comfortable.) Slip the holes in the hanger onto the protruding bolts on the leg assembly, and follow up with the large (1-1/2" diameter) washers, and 5/16 locknuts. Tighten all the way up, then loosen 1/4th turn. On the front hangers use your pliers on the inside and the socket on the outside to tighten.

Put a couple drops of oil or WD40 on each bearing periodically. Enjoy your glider.

- ***When finished with glider go over and tighten all nuts with pliers or socket set.***
- ***Periodically tighten rocking glider to maintain stability.***

Part List for Rocking Glider

1 – Seat Assembly	2, 3 or 4 – 5-1/2" bolts depending on length of glider	
1 – Back Assembly	6, 8 or 10 – small washers depending on length of glider	
2 – Feet	4 – 3" Hex Head Bolts	8 – Large Washers
1 – Crossmember	2 – 3" Carriage Bolts	8, 9 or 10 – 1/4" Nuts
2 – Arm & Leg Assemblies (Left & Right)	8 – 2-1/2" Screws	4 – 5/16" Locknuts
	4 – 2" Screws	

Tools needed for assembly:

- Drill
- Pliers and ratchet w/ 7/16" socket
- Hammer For Light Tapping
- 1/2" socket for locknuts

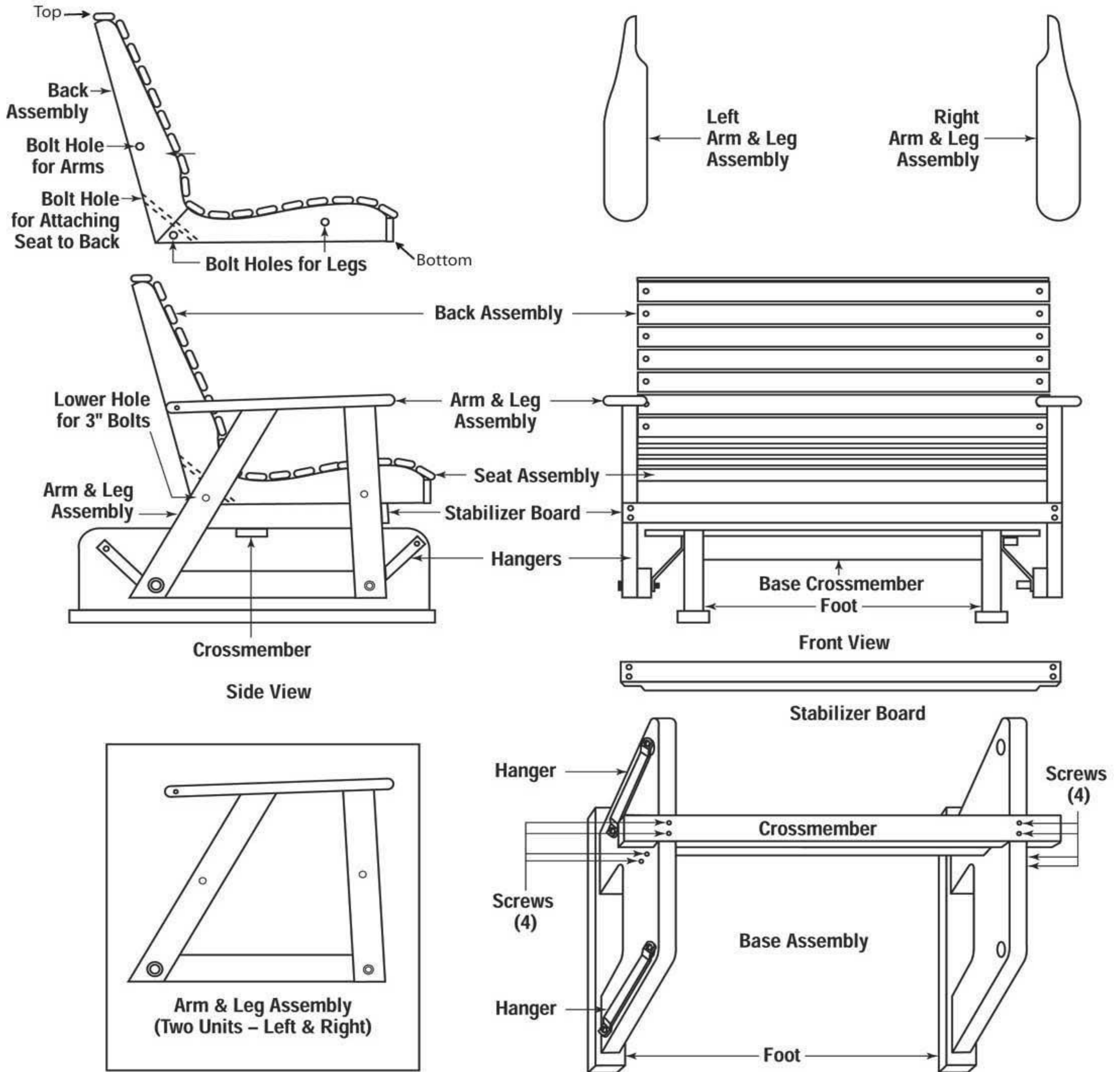

Assembly Instructions for Cedar Patio Tables

Item: WF1112CVD, WRF3200COLCVD, WRF3230SETCVD, WRF1120COLCVD

Tools needed for assembly:

Drill.

Pliers and 1/4" socket set.

Hammer for tapping bolts and screws.

Step 1 Bolt the (4) legs to the top with (4) 3# Truss head bolts.
Use a washer under the head and nut both. Finger tighten for now.

Step 2 Fasten the shelf to the legs with the remaining bolts, nuts, & washer.
Tighten all 8 bolts firmly.

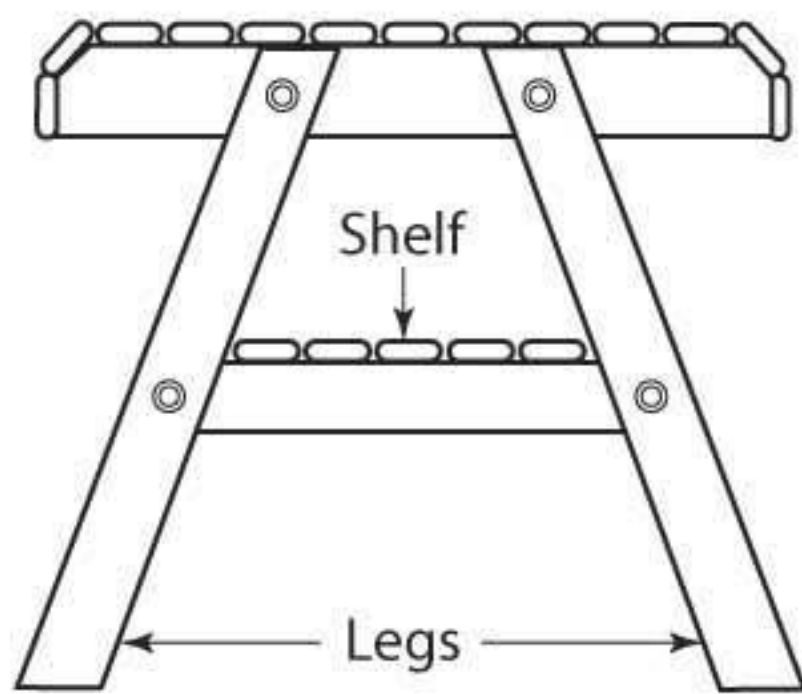

Side View

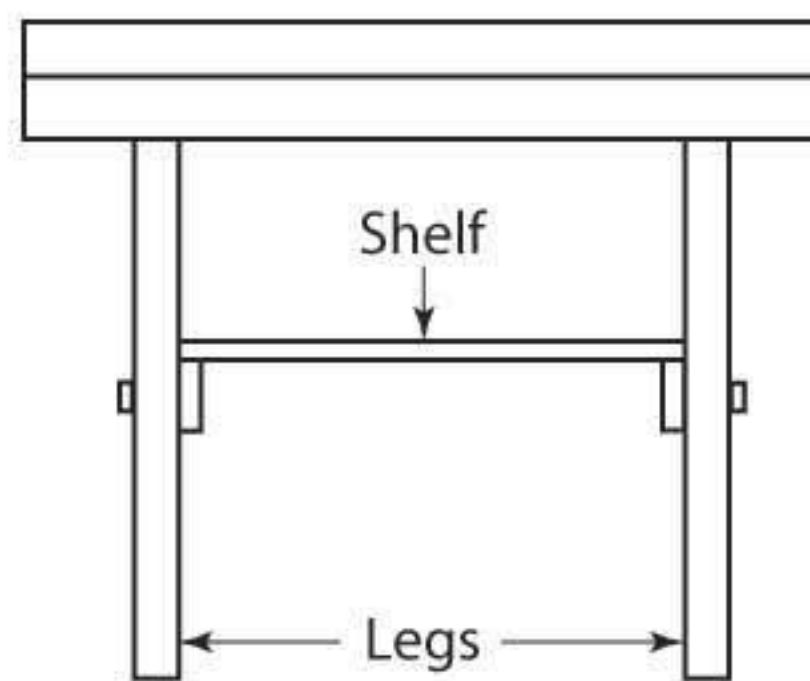

Front View

Note: Due to product variations, the parts list may be different than what you actually receive with your product.

Parts List For Patio Table

1 – Table top

1 – Shelf

4 – Legs

8 – 1/4 x 3 Truss Head Bolts

8 – 1/4" Nuts

16 – 1/4" x 1 Washers