

Adirondack Rocking Chair Assembly Instructions

Step 1

Fasten the front legs to the seat supports with 3" hex bolts, being sure the long end is toward the front (see diagram). Use a large washer on each end of the bolts. Tighten the nuts by hand until just snug (DO NOT TIGHTEN ALL THE WAY). Now insert two 2 1/2" screws per side into the pre-drilled holes on the front of the seat and turn them until the heads are sunk in even with the wood. Then go back and tighten the bolts the rest of the way.

Step 2

Fasten the back legs to the inner sides of the seat supports using 3" hex bolts with washers on each end and a nut to secure them. The flat end of each back leg should be at the bottom. Make sure they are facing the correct way so the seat back can rest squarely against them.

Step 3

Place the seat back so that the upper back support rests on top of the back legs. Adjust the back legs until lower back support fits into the notches on the back of the seat. Fasten four 3" screws through the upper back support and into the top of the back legs. Next, fasten four screws through the lower back support and down into the seat support.

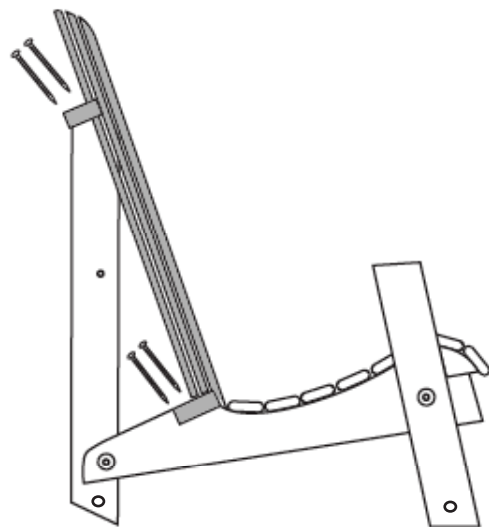

Step 4

Fasten the arms first to the back legs using 3-1/2" carriage bolts, using a large washer under the nut only. Now put two 2 1/2" screws (per side) down through the predrilled holes in the arm and into the front legs.

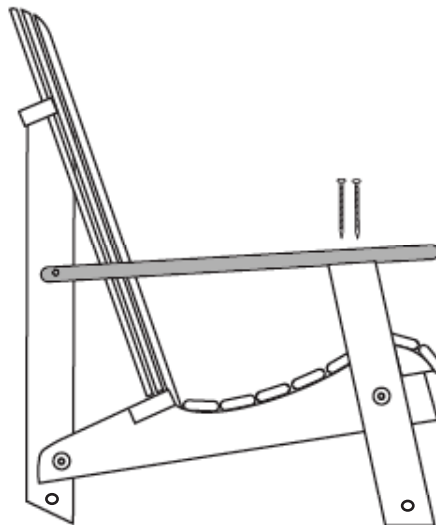

Instructions used for item code: WF5110

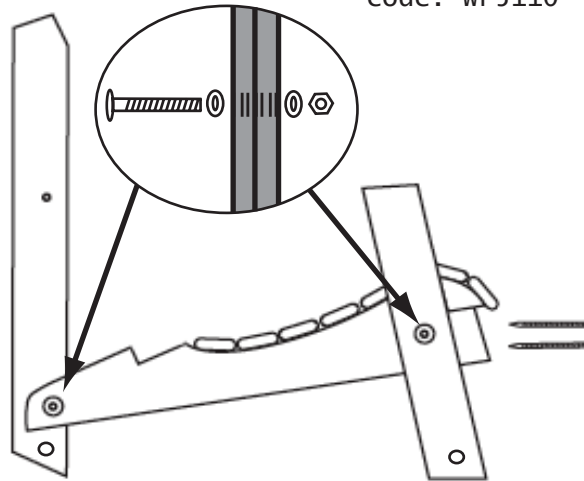

Tools Required for Assembly

Hammer
Ratchet with 7/16" Socket
Pliers (suggested)
#2 Drill Bit (supplied)

Parts List

2 Rear Legs
2 Front Legs
2 Rocker Feet
2 Arm Rests
1 Seat Back
1 Seat

The item can be found on www.CedarwoodFurniture.com

Call 877-595-8537 to order

Hardware

8 1/4 x 3" Hex Head Bolts
2 1/4" x 3 1/2" inch Carriage Bolts
18 1/4" Fender Washers
10 1/4" Nuts
8 3" Screws
8 2 1/2" Screws

Step 5

The last step is to attach the rocker feet using 3" hex bolts. Make sure the front end of each rocker foot is on the inside of the front leg and that the back end of each rocker foot is on the outside of the back legs. Be sure there is a washer on each end of the bolt before securing with a nut.

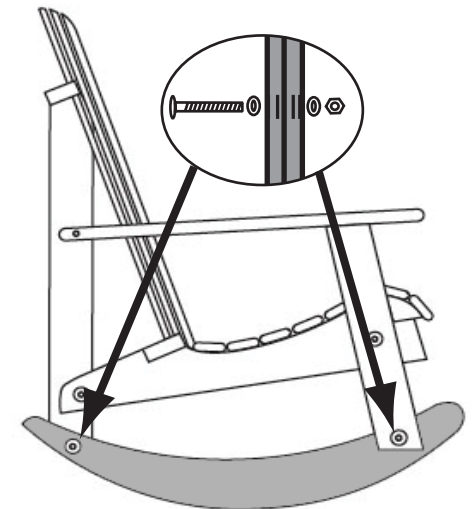

Assembly Instructions for Cedar End Tables & Coffee Tables

Tools needed for assembly:

Drill.

Pliers and 1/4" socket set.

Hammer

The item can be found on
www.CedarwoodFurniture.com

Call 877-595-8537 to order

Step 1 Bolt the 4 legs to the top with (4) 3" bolts.

Use a washer under the head, and the nut both. Finger tighten for now.

Step 2 Bolt the (2) #1 braces to the inside of the legs with the rest of the bolts, nuts & washers.

Tighten all 8 bolts firmly.

Step 3 Hold the #2 brace in place between the (2) #1 braces and tap the (4) screws through the holes provided, with a hammer, then turn them the rest of the way in with a Phillips screwdriver.

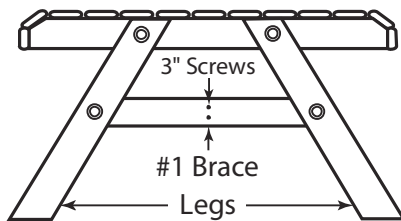

Side View

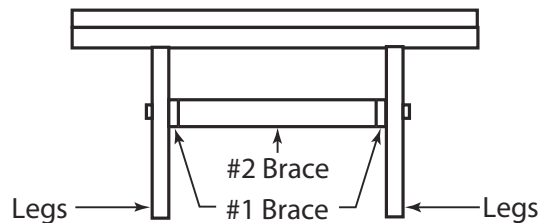

Front View

Note: Due to product variations, the parts list may be different than what you actually receive with your product.

Parts List For End Table and Coffee Table

1 – Table Top

4 – Legs

2 – #1 Braces

1 – #2 Brace

Hardware

8 – 3" Bolts

16 – Washers

8 – 1/4" Nuts

4 – 3" Screws