

# Instructions for 46", 58", 70", & 94" Red Cedar Contoured Backed Bench

Item: ELY46CTT2B2BBCVD, ELY58CTT2B2BBCVD, ELY70CTT2B2BBCVD, ELY94CTT2B2BBCVD, ELY46CTT1B1BBCVD, ELY58CTT1B1BBCVD, ELY70CTT1B1BBCVD, ELY94CTT1B1BBCVD, ELY46CTT4BBCVD, ELY58CTT4BBCVD, ELY70CTT4BBCVD, ELY94CTT4BBCVD

## Tools Required for Assembly

7/16" Socket or Adjustable Wrench  
2# Squarehead Bit (included)  
Hammer for tapping bolts and screws.

## Hardware List

8- 1/4 x 3" Hex Bolts  
8- 1/4" Hex Nuts  
16- 1/4 x 1" Fender Washers  
4- 3" Screws  
4- 2 1/2" Screws

## Parts List

1- Bench Top  
1- Bench Back  
2- Bench Legs

The item can be found on  
[www.CedarwoodFurniture.com](http://www.CedarwoodFurniture.com)

Call 877-595-8537 to order

Hex Bolts 

Screw 

Fender Washer 

Nut 

Pre-drilled Hole 

### Step 1:

Lay the table top upside down on a clean flat surface. Place each leg on the outside, aligning it with the pre-drilled holes. Tighten the bolts.

### Step 2:

Now put the 3" screws in the small pre-drilled holes.

### Step 3:

Tip the bench on its side and place the bench back on the outside of the bench, align holes, tighten bolts, and put 2 1/2" screws in small pre-drilled holes.

# Instructions for 46", 58", 70", & 94" Red Cedar Contoured Backed Bench

Item: ELY46CTT2B2BBCVD, ELY58CTT2B2BBCVD, ELY70CTT2B2BBCVD, ELY94CTT2B2BBCVD, ELY46CTT1B1BBCVD, ELY58CTT1B1BBCVD, ELY70CTT1B1BBCVD, ELY94CTT1B1BBCVD, ELY46CTT4BBCVD, ELY58CTT4BBCVD, ELY70CTT4BBCVD, ELY94CTT4BBCVD

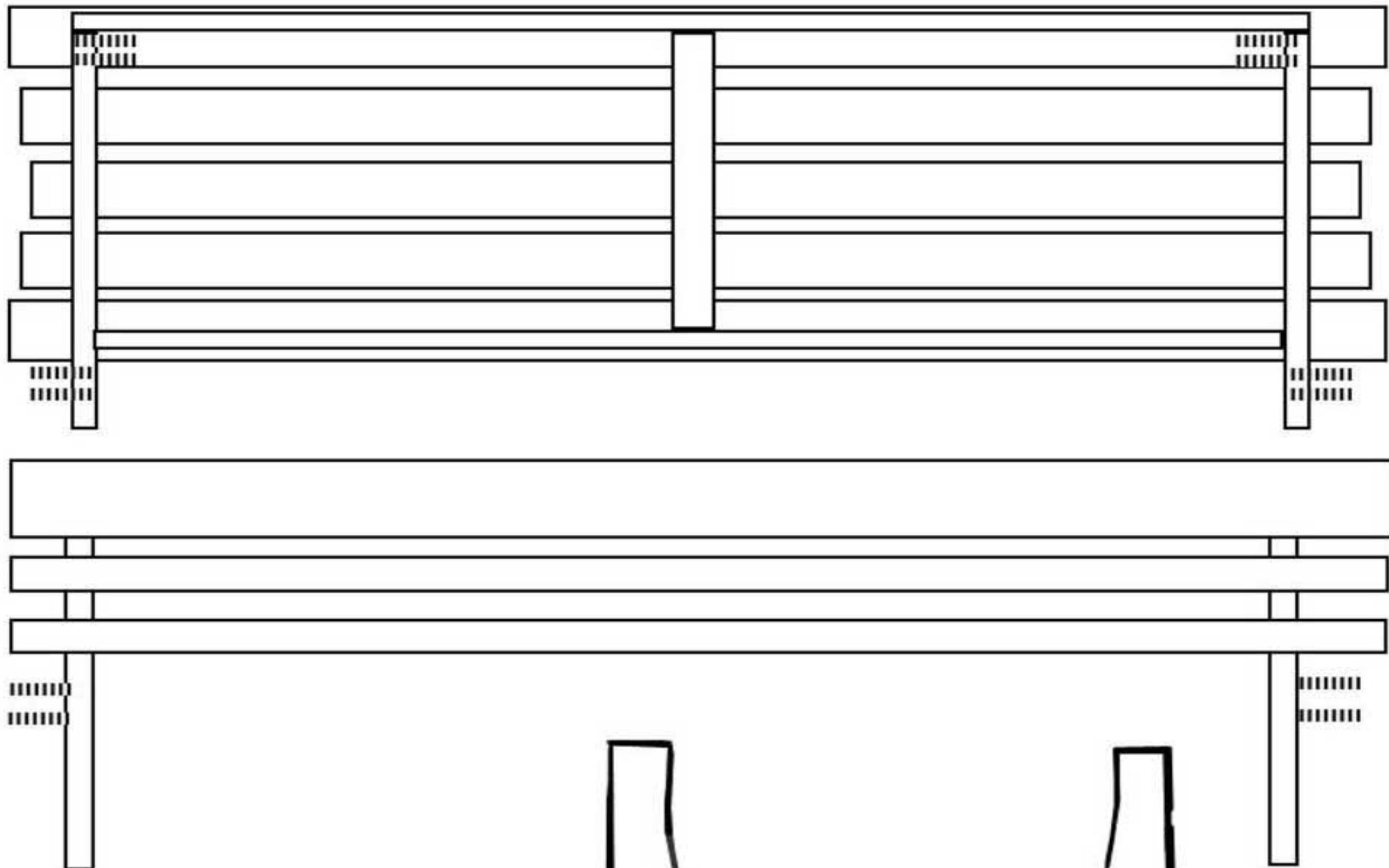

2- 3" Screws  
for each side

4- 3" Bolts  
for each side

2 1/2" Screws  
for each side

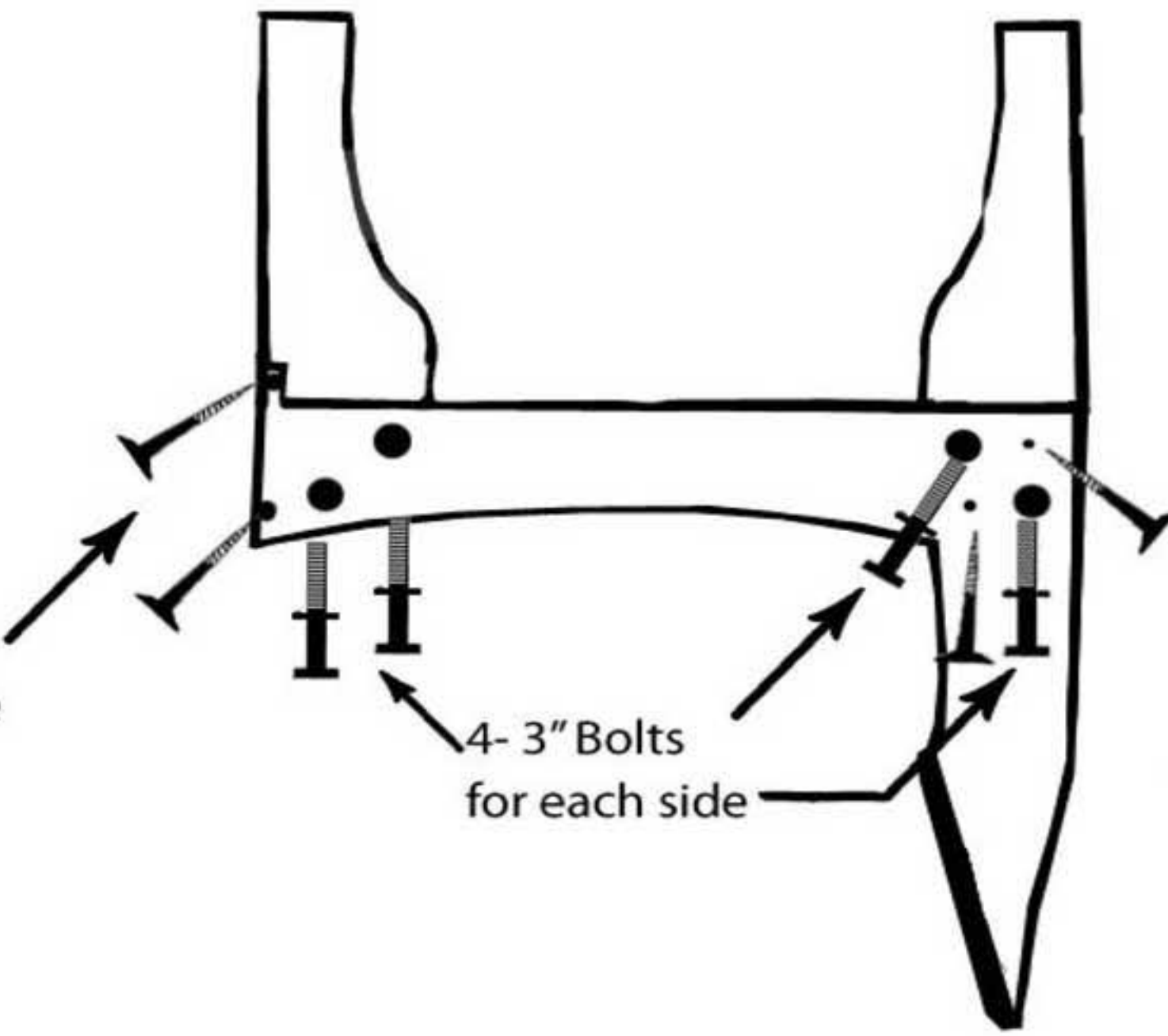

# Chickadee Table Assembly Instructions

Item: ELY46CTT4BBCVD, ELY58CTT4BBCVD, ELY70CTT4BBCVD, ELY94CTT4BBCVD

## Tools Required for Assembly

7/16" Socket or Adjustable Wrench  
2# Squarehead Bit (included)  
Hammer for tapping bolts and screws.

## Hardware List

8- 2 1/2" Hex Bolts  
8- Hex Nuts  
24- 1/4 x 1" Fender Washers  
8- 1/4 x 2 1/2" Lags

## Parts List

1- Table Top  
4- Table Legs

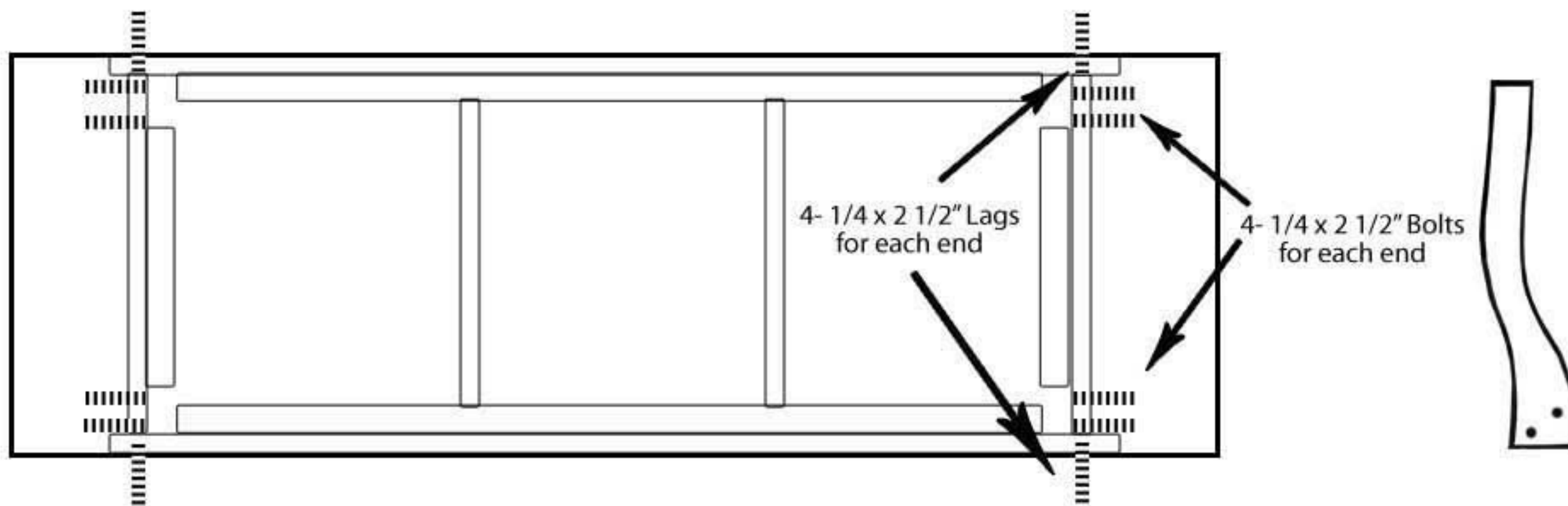
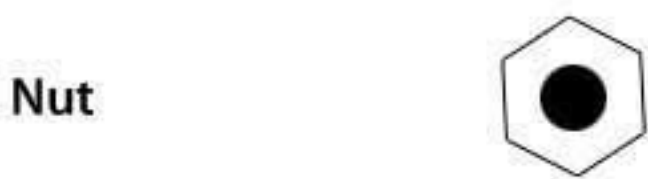

### Step 1:

Lay the table top upside down on a clean flat surface. Place each leg on the outer side into the notched out cross member using the 2 1/2" bolt.

### Step 2:

Next put the 2 1/2" Lags through the side rail piece into the leg.

### Step 3:

Repeat with each leg.

# Instructions For 32", 46", 58", 70", & 94" Red Cedar Contour Bench

Item: ELY46CTT4B-2CVD, ELY58CTT4B-2CVD, ELY70CTT4B-2CVD, ELY94CTT4B-2CVD, ELY46CTT2B2BBCVD, ELY58CTT2B2BBCVD, ELY70CTT2B2BBCVD, ELY94CTT2B2BBCVD, ELY46CTT1B1BBCVD, ELY58CTT1B1BBCVD, ELY70CTT1B1BBCVD, ELY94CTT1B1BBCVD

## Tools Required for Assembly

7/16" Socket or Adjustable Wrench  
2# Squarehead Bit (included)  
Hammer for tapping bolts and screws.

## Hardware List

8- 1/4 x 3" Hex Bolts  
8- 1/4" Hex Nuts  
16- 1/4 x 1" Fender Washers  
8- 3" Screws

## Parts List

1- Bench Top  
4- Bench Legs

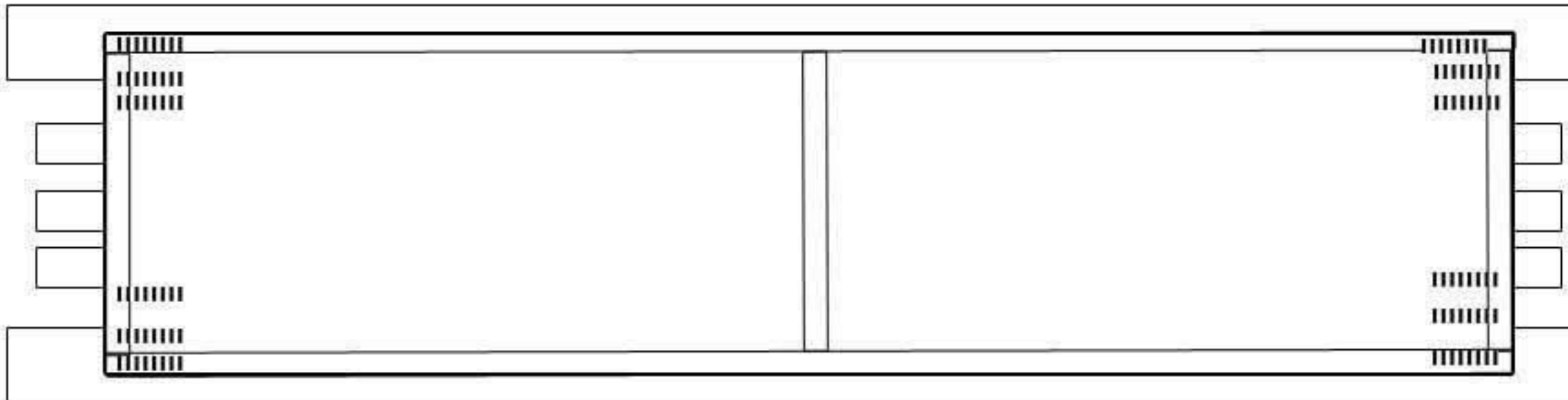
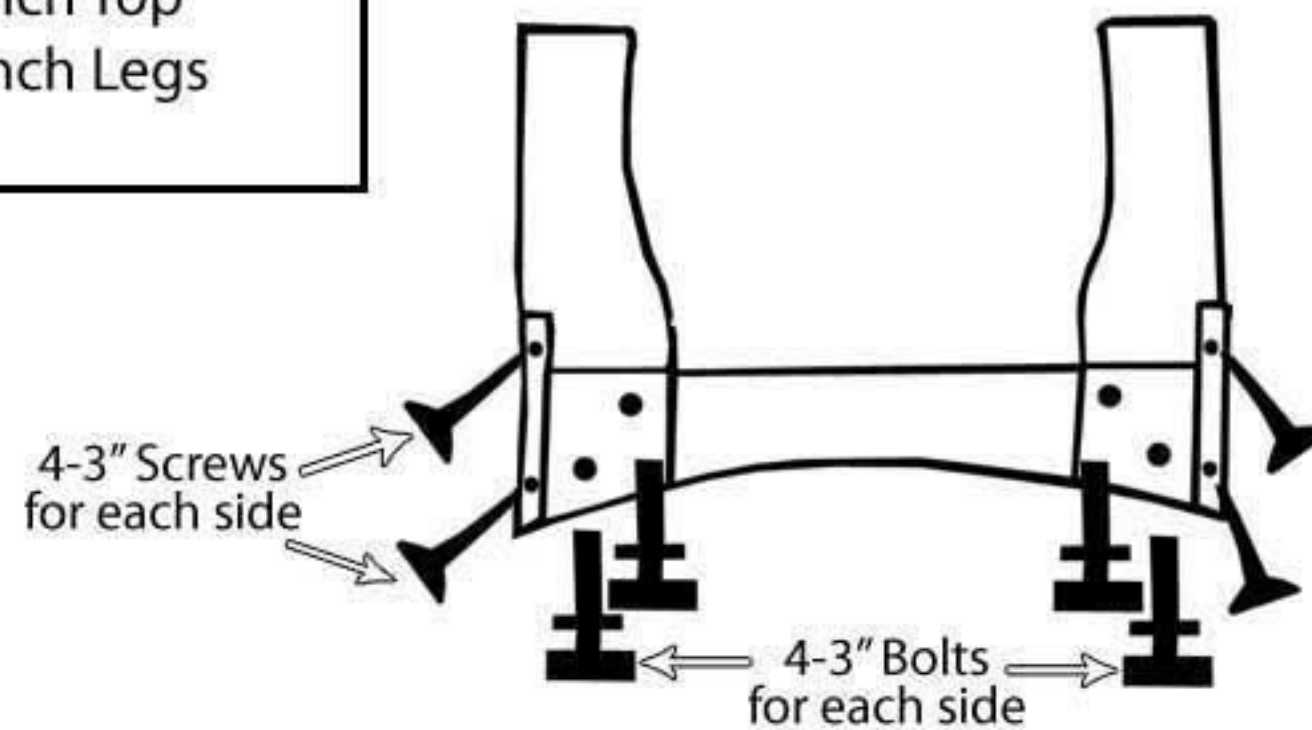
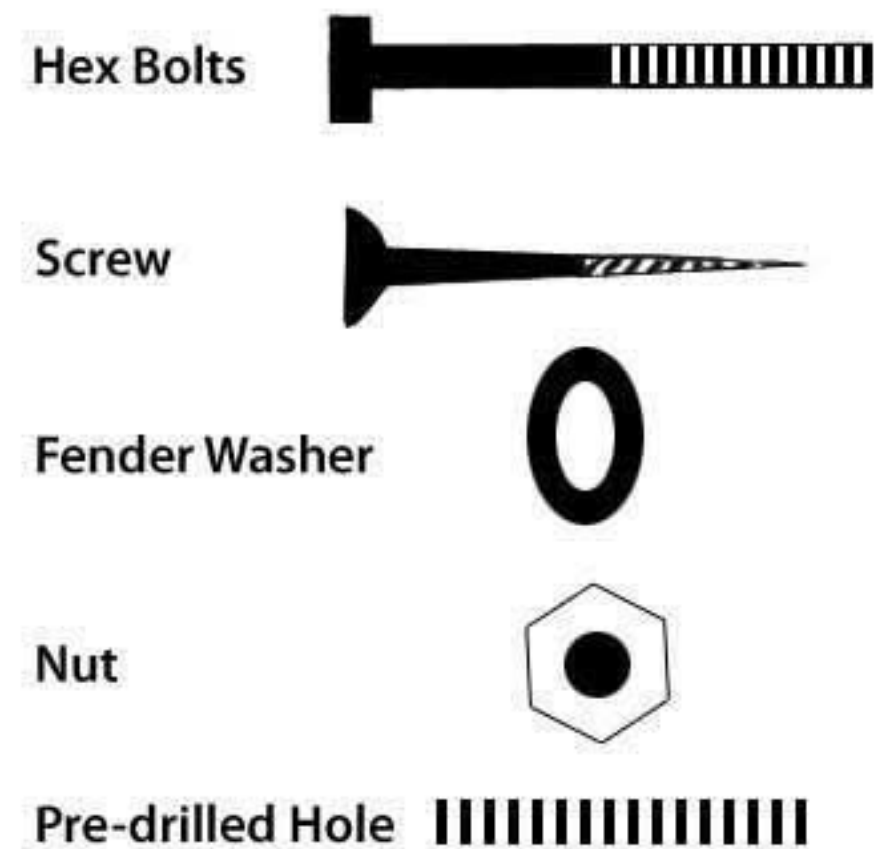

### Step 1:

Lay the bench with the top upside down on a clean flat surface. Place each bench leg on the outside aligning with the predrilled holes. Tighten the bolts.

### Step 2:

Next put the 3" screws in the small predrilled holes. It is easier to put the bolt part of the way into the predrilled hole and then tap the rest of the way with a hammer.

### Step 3:

Repeat with each leg.